

1. SPIRAL WOUND GASKETS

PROPERTIES AND APPLICATION

Spiral wound gaskets are special semi-metallic gaskets of great resilience, therefore they are very suitable for applications featuring heavy operating conditions. Spiral wound gaskets are manufactured by spirally winding a V-shaped metal strip and a strip of non-metallic filler material. The metal strip holds the filler, providing the gasket with mechanical resistance and resilience. Spiral wound gaskets can be reinforced by an outer centering ring and/or inner retaining ring. The outer centering ring controls the compression and holds the gasket centrally within the bolt circle. The inner retaining ring increases the axial rigidity and resilience of the gasket. Spiral wound gaskets should always be in contact with the flange and should not protrude into the pipe or project from the flange. Spiral wound gaskets can be used for sealing flange joints, manhole and handhold covers, tube covers, boilers, heat exchangers, pressure vessels, pumps, compressors and valves; in industries such as petrochemical, pharmaceutical, shipbuilding, and food processing, in power industries and nuclear power stations. They are ideal for steam, oil, liquids, gases, acids, alkalines, various organic mediums and solvents.

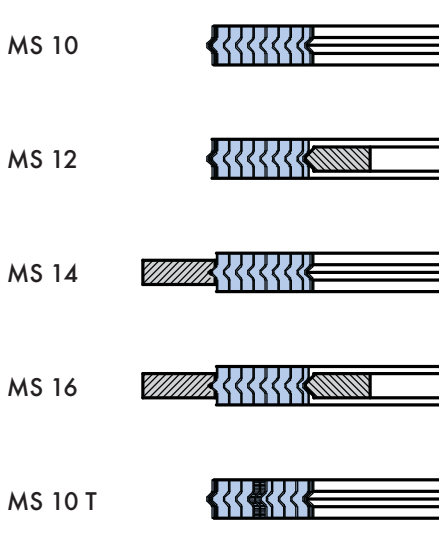

ADVANTAGES

- Sealing under heavy operating conditions.
- Strong stress compensation, stable and reliable sealing performance even under frequent pressure fluctuation condition.
- Solid construction provides stability and sealability even when the sealing surfaces are slightly corroded or bent.
- Easy installation.

SHAPE AND CONSTRUCTION

Spiral wound gaskets are produced in several styles and combination of materials to fit the most stringent application. Spiral wound gaskets are usually of circular shape, however we can produce them in other shapes such as: oval, rectangular, with round corners, etc. Our standard production program comprises a range of spiral wound gaskets with inner diameters of 10 mm to 3000 mm and a nominal thickness of 3.2 mm, 4.5 mm and 6.5 mm. Spiral wound gaskets of non-standard dimensions and shapes, and larger diameters are available on request.

Gasket standard styles:

- Gaskets without guide and inner ring (Type MS 10)
- Gaskets without guide and inner ring (Type MS 10T)*
- Gaskets with inner ring (Type MS 12)
- Gaskets with guide (outer) ring (Type MS 14)
- Gaskets with guide and with inner ring (Type MS 16)

* With PTFE sealing zone

1. SPIRAL WOUND GASKETS

Metallic strip

Standard thickness of the metallic strip is 0.2 mm (0.18).

MATERIALS FOR METALLIC STRIP	
ASTM	DIN Material No.
AISI 304	1.4301
AISI 316, 316 L	1.4401, 1.4404
AISI 321	1.4541
AISI 316 Ti	1.4571
Monel (NiCu30Fe)	2.4360

Other alloys available on request.

Filler

Filler is normally used for thicknesses from 0.5 mm to 0.6 mm.

- Flexible graphite 98%
- Flexible graphite 99.85%
- PTFE, EPTFE
- Ceramic, Micalit

Centering ring

The centering ring does not come into direct contact with contained fluid. It is normally made of carbon steel and electro plated or painted to avoid corrosion. Other materials are available on request.

Inner ring

Inner ring is used to avoid excessive compression due to high seating stress in high-pressure service and it is also used to reduce turbulence in the flange area. It is normally made of the same material as the gasket metallic strip.

DIMENSIONS

Manufacturing sizes

This limitations are general and can vary according to the special customer requirements.

LIMITATIONS FOR MANUFACTURING DIMENSIONS			
Thickness [mm]	Max diameter d_3 [mm]	Maximum width - b_G [mm]	
		Graphite	PTFE
2.5	300	16	13
3.2	700	22	19
4.5	1500	30	24
6.5	3000	35	24
7.2	3000	30	24

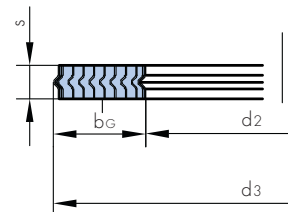

Thickness

The standard manufacturing thicknesses for spiral wound gaskets are: 3.2 mm; 4.5 mm; 6.5 mm (measured across metallic strip not including the filler, which protrudes 0.2 - 0.3 mm beyond the metal).

Manufacturing tolerances

The tolerance of the gasket diameters (d_1 , d_2 , d_3 , d_4 , s , s_1) are stipulated by ASME B 16.20 and EN 1514-2 standards. The gaskets designed for non-standard flanges meet the recommendations by the ASME B 16.20.

Dimensions

The dimensions of the standard SWG meet the ASME, BS and EN (DIN) standards.



I. SPIRAL WOUND GASKETS

DN (mm)	NPS (in)
15	1/2
20	3/4
25	1
32	1 1/4
40	1 1/2
50	2
65	2 1/2
80	3
90	3 1/2
100	4
125	5
150	6
200	8
250	10
300	12
350	14
400	16
450	18
500	20
550	22
600	24

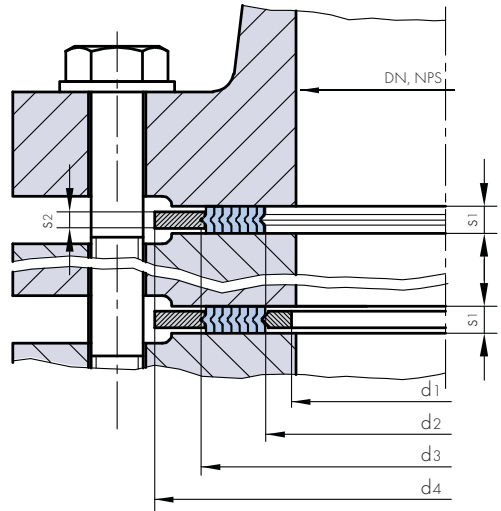

SWG for BS 1560 and ASME B 16.5 flanges

NPS (in)	d1 (mm)		d2 (mm)		d3 (mm)	d4 (mm)						
	150-400	600-2500	150-400	600-2500		150	300	400	600	900	1500	2500
1/2	12.7	12.7	19.1	19.1	31.8	44.4	50.8	50.8	50.8	60.3	60.3	66.7
3/4	20.6	20.6	27	27	39.7	53.9	63.5	63.5	63.5	66.7	66.7	73
1	27	27	33.3	33.3	47.6	63.5	69.8	69.8	69.8	76.2	76.2	82.5
1 1/4	41.3	39.7	47.6	46	60.3	73	79.4	79.4	79.4	85.7	85.7	101.6
1 1/2	49.2	47.6	55.6	54	69.9	82.5	92.1	92.1	92.1	95.2	95.2	114.3
2	61.9	60.3	71.4	69.9	85.7	101.6	108	108	108	139.7	139.7	142.8
2 1/2	74.6	73	84.1	82.6	98.4	120.6	127	127	127	161.9	161.9	165.1
3	95.3	92.1	104.8	101.6	120.7	133.4	146.1	146.1	146.1	165.1	171.5	193.7
3 1/2	108	104.8	117.5	114.3	133.4	158.8	161.9	158.7	158.7			
4	117.5	114.3	130.2	127	149.2	171.5	177.8	174.6	190.5	203.2	206.4	231.7
5	144.5	141.3	157.2	154	177.8	193.7	212.7	209.5	238.1	244.5	250.8	276.2
6	171.5	168.3	184.2	181	209.6	219.1	247.7	244.5	263.5	285.8	279.4	314.3
8	222.3	219.1	235	231.8	263.5	276.2	304.8	301.6	317.5	355.6	349.3	384.1
10	276.2	269.9	288.9	282.6	317.5	336.5	358.8	355.6	396.9	431.8	431.8	473
12	330.2	323.8	342.9	336.5	374.6	406.4	419.1	415.9	454	495.3	517.5	546.1
14	361.9	355.6	374.6	368.3	406.4	447.7	482.6	479.4	488.9	517.5	574.7	
16	412.7	406.4	425.4	419.1	463.5	511.2	536.6	533.4	561.9	571.5	638.1	
18	466.7	460.4	479.4	473.1	527	546.1	593.7	590.5	609.6	635	701.7	
20	517.5	511.2	530.2	523.9	577.8	603.2	650.9	644.5	679.5	695.3	752.4	
22	574.4	568.4	587.4	581.1	635	657.2	701.7	698.5	730.3			
24	622.3	615.9	635	628.6	685.8	714.4	771.5	765.2	787.4	835	898.5	

EN 1514-2 gaskets for EN 1092-1 flanges

DN (mm)	d1 (mm)	d2 (mm)	d3 (mm)	d4 (mm)										
				PN 10-320	PN 10-320	PN 10-40	PN 64-320	PN 10	PN 16	PN 25	PN 40	PN 64	PN 100	PN 160
10	18	24	36	36	46	46	46	46	56	56	56	67	67	67
15	22	28	40	40	51	51	51	51	61	61	61	72	72	78
20	27	33	47	47	61	61	61	61	72	72	72	77	77	
25	34	40	54	54	71	71	71	71	82	82	82	83	92	104
32	43	49	65	65	82	82	82	82	90	90	90	100		
40	48	54	70	70	92	92	92	92	103	103	103	109	119	135
50	57	66	84	84	107	107	107	107	113	119	119	124	134	150
65	73	82	102	104	127	127	127	127	137	143	143	153	170	192
80	86	95	115	119	142	142	142	142	148	154	154	170	190	207
100	108	120	140	144	162	162	168	168	174	180	180	202	229	256
125	134	146	168	172	192	192	194	194	210	217	217	242	274	301
150	162	174	196	200	217	217	224	224	247	257	257	284	311	348
175	183	195	221	227	247	247	254	265	277	287	284	316	358	402
200	213	225	251	257	272	272	284	290	309	324	324	358	398	442
250	267	279	307	315	327	328	340	352	364	391	388	442	488	
300	318	330	358	366	377	383	400	417	424	458	458	538		
350	363	375	405	413	437	443	457	474	486	512				
400	414	426	458	466	488	495	514	546	543	572				
450	460	478	526	551	558	567	574	578	534					
500	518	530	566	574	593	617	624	628	657	704				
600	618	630	666	674	695	734	731	747	764	813				
700	718	730	770	778	810	804	833	852	879					
800	818	830	874	882	917	911	942	974	988					
900	910	930	974	982	1017	1011	1042	1084	1108					
1000	1010	1030	1078	1086	1124	1128	1154	1194	1220					
1200	1210	1230	1280	1290	1341	1342	1364	1398	1452					
1400	1420	1450	1510		1548	1542	1578	1618						
1600	1630	1660	1720		1772	1764	1798	1830						
1800	1830	1860	1920		1972	1964	2000							
2000	2020	2050	2120		2182	2168	2230							
2200	2230	2260	2330		2384	2376								
2400	2430	2480	2530		2594									
2600	2630	2660	2730		2794									
2800	2830	2860	2930		3014									
3000	3030	3060	3130		3228									

1. SPIRAL WOUND GASKETS

ASME B 16.20 gaskets for ASME B 16.5 flanges

NPS (in)	d1 (mm)					d2 (mm)					d3 (mm)		d4 (mm)						
	150-300	400-600	900	1500	2500	150-300	400-600	900	1500	2500	150-600	900-2500	150	300	400	600	900	1500	2500
1/2	14.2	14.2	14.2	14.2	14.2	19.1	19.1	19.1	19.1	19.1	31.8	31.8	47.8	54.1	54.1	54.1	63.5	63.5	69.9
3/4	20.6	20.6	20.6	20.6	20.6	25.4	25.4	25.4	25.4	25.4	39.6	39.6	57.2	66.8	66.8	66.8	69.9	69.9	76.2
1	26.9	26.9	26.9	26.9	26.9	31.8	31.8	31.8	31.8	31.8	47.8	47.8	66.8	73.2	73.2	73.2	79.5	79.5	85.9
1 1/4	38.1	38.1	38.1	33.3	33.3	47.8	47.8	39.6	39.6	39.6	60.5	60.5	76.2	82.6	82.6	82.6	88.9	88.9	104.9
1 1/2	44.5	44.5	44.5	41.4	41.4	54.1	54.1	47.8	47.8	47.8	69.9	69.9	85.9	95.3	95.3	95.3	98.6	98.6	117.6
2	55.6	55.6	55.6	52.3	52.3	69.9	69.9	58.7	58.7	58.7	85.9	85.9	104.9	111.3	111.3	111.3	143.0	143.0	146.1
2 1/2	66.5	66.5	66.5	63.5	63.5	82.6	82.6	69.9	69.9	69.9	98.6	98.6	124.0	130.3	130.3	130.3	165.1	165.1	168.4
3	81.0	81.0	81.0	81.0	81.0	101.6	101.6	95.3	92.2	92.2	120.7	120.7	136.7	149.4	149.4	149.4	168.4	174.8	196.9
4	106.4	106.4	106.4	106.4	106.4	127.0	127.0	120.7	117.6	117.6	149.4	149.4	174.8	181.1	177.8	193.8	206.5	209.6	235.0
5	131.8	131.8	131.8	131.8	131.8	155.7	147.6	147.6	143.0	143.0	177.8	177.8	196.9	215.9	212.9	241.3	247.7	254.0	279.4
6	157.2	157.2	157.2	157.2	157.2	182.6	174.8	174.8	171.5	171.5	209.6	209.6	229.4	251.0	247.7	266.7	289.1	282.7	317.5
8	215.9	209.6	196.9	196.9	196.9	233.4	225.6	222.3	215.9	215.9	263.7	257.3	279.4	308.1	304.8	320.8	358.9	352.6	387.4
10	268.2	260.4	246.1	246.1	246.1	287.3	274.6	276.4	266.7	270.0	317.5	311.2	339.9	362.0	358.9	400.1	435.1	435.1	476.3
12	317.5	317.5	292.1	292.1	292.1	339.9	327.2	323.9	323.9	317.5	374.7	368.3	409.7	422.4	419.1	457.2	498.6	520.7	549.4
14	349.3	349.3	320.8	320.8		371.6	362.0	356.6	362.0		406.4	400.1	450.9	485.9	482.6	492.3	520.7	577.9	
16	400.1	400.1	374.7	368.3		422.4	412.8	412.8	406.7		463.6	457.2	514.4	539.8	536.7	565.2	574.8	641.4	
18	449.3	449.3	425.5	425.5		474.7	469.9	463.6	463.6		527.1	520.7	549.4	596.9	593.9	612.9	638.3	704.9	
20	500.1	500.1	482.6	476.3		525.5	520.7	520.7	514.4		577.9	571.5	606.6	654.1	647.7	682.8	698.5	755.7	
24	603.3	603.3	590.6	577.9		628.7	628.7	628.7	616.0		685.8	679.5	717.6	774.7	768.4	790.7	838.2	901.7	

ASME B 16.20 gasket for ASME B 16.47 Series B flanges

NPS (in)	d1 (mm)					d2 (mm)					d3 (mm)					d4 (mm)				
	150	300	400	600	900	150	300	400	600	900	150	300	400	600	900	150	300	400	600	900
26	654.1	654.1	654.1	644.7	666.8	673.1	673.1	666.8	663.7	692.2	698.5	711.2	698.5	714.5	749.3	725.4	771.7	746.3	765.3	838.2
28	704.9	704.9	701.8	692.2	717.6	723.9	723.9	714.5	704.9	743.0	749.3	762.0	749.3	755.7	800.1	776.2	825.5	800.1	819.2	901.7
30	755.7	755.7	752.6	752.6	781.1	774.7	774.7	765.3	778.0	806.5	800.1	812.8	806.5	828.8	857.3	827.0	886.0	857.3	879.6	958.3
32	806.5	806.5	800.1	793.8	838.2	825.5	825.5	812.8	831.9	863.6	850.9	863.6	858.5	882.7	914.4	881.1	939.8	911.4	933.5	1016.0
34	857.3	857.3	850.9	850.9	895.4	876.3	876.3	866.9	889.0	920.8	908.1	914.4	911.4	939.8	971.6	935.0	993.9	962.2	997.0	1073.2
36	908.1	908.1	898.7	901.7	920.8	927.1	927.1	917.7	939.8	946.2	958.9	962.2	965.2	990.6	997.0	987.6	1047.8	1022.4	1047.8	1124.0
38	958.9	971.6	952.5	952.5	1009.7	974.6	1009.7	971.6	990.6	1035.1	1009.7	1022.4	1041.4	1085.9	1044.7	1019.6	1098.6	1073.2	1104.9	1200.2
40	1009.7	1003.3	1000.3	1009.7	1060.5	1022.4	1060.5	1025.7	1047.8	1098.6	1063.8	1098.6	1076.5	1098.6	1149.4	1095.5	1149.4	1127.3	1155.7	1251.0
42	1060.5	1054.1	1051.1	1066.8	1111.3	1079.5	1111.3	1076.5	1104.9	1149.4	1114.6	1149.4	1127.3	1155.7	1200.2	1146.3	1200.2	1178.1	1219.2	1301.8
44	1111.3	1124.0	1104.9	1111.3	1155.7	1124.0	1162.1	1130.3	1162.1	1206.5	1165.4	1200.2	1181.1	1212.9	1257.3	1197.1	1251.0	1231.9	1270.0	1368.6
46	1162.1	1178.1	1168.4	1162.1	1219.2	1181.1	1216.2	1193.8	1212.9	1270.0	1224.0	1254.3	1244.6	1263.7	1320.8	1255.7	1317.8	1289.1	1327.2	1435.1
48	1212.9	1231.9	1206.5	1219.2	1270.0	1231.9	1263.7	1244.6	1270.0	1320.8	1270.0	1311.4	1295.4	1320.8	1371.6	1306.6	1368.6	1346.2	1390.7	1485.9
50	1263.7	1267.0	1257.3	1270.0		1282.7	1317.8	1295.4	1320.8		1325.6	1355.9	1346.2	1371.6		1357.4	1419.4	1403.4	1447.8	
52	1314.5	1317.8	1308.1	1320.8		1335.5	1368.6	1346.2	1371.6		1376.4	1406.7	1397.0	1422.4		1408.2	1470.2	1454.2	1498.6	
54	1365.3	1365.3	1352.6	1378.0		1384.3	1403.4	1403.4	1428.8		1422.4	1454.2	1454.2	1479.6		1463.8	1530.4	1517.7	1555.8	
56	1422.4	1428.8	1403.4	1428.8		1444.8	1479.6	1454.2	1479.6		1477.8	1524.0	1505.0	1530.4		1514.6	1593.8	1568.5	1612.9	
58	1478.0	1484.4	1454.2	1473.2		1500.4	1535.2	1505.0	1536.7		1528.8	1573.3	1555.8	1587.5		1579.6	1655.8	1619.3	1663.7	
60	1535.2	1557.3	1517.7	1530.4		1557.3	1589.0	1568.5	1593.9		1586.0	1630.4	1619.3	1644.7		1630.4	1706.6	1682.8	1733.6	

ASME B 16.20 gaskets for ASME B 16.47 Series A flanges

NPS (in)	d1 (mm)					d2 (mm)					d3 (mm)					d4 (mm)				
	150	300	400	600	900	150	300	400	600	900	150	300	400	600	900	150	300	400	600	900
26	654.05	654.05	660.4	647.7	666.75	673.1	685.8	685.8	685.8	685.8	704.85	736.6	736.6	736.6	736.6	774.7	835.15	831.85	866.9	882.65
28	704.85	704.85	711.2	698.5	711.2	723.9	736.6	736.6	736.6	736.6	755.65	787.4	787.4	787.4	787.4	831.85	898.65	892.3	914.4	946.15
30	755.65	755.65	755.65	755.65	774.7	774.7	793.75	793.75	793.75	793.75	806.45	844.55	844.55	844.55	844.55	882.65	952.5	946.15	971.55	1009.65
32	806.45	806.45	812.8	812.8	825.5	850.9	850.9	850.9	850.9	850.9	860.55	901.7	901.7	901.7	901.7	939.8	1006.6	1003.3	1022.4	1073.15
34	857.25	857.25	863.6	863.6	876.3	901.7	901.7	901.7	901.7	911.35	952.5	952.5	952.5	952.5	990.6	1057.4	1054.1	1073.2	1136.65	
36	908.05	908.05	917.7	917.7	920.75	927.1	955.8	955.8	958.85	968.5	1006.6	1006.6	1006.6	1009.65	1047.75	1117.6	1117.6	1130.3	1200.15	
38	958.85	952.5	952.5	952.5	1009.65	977.9	977.9	971.55	990.6	1035.05	1019.3	1016	1022.35	1041.4	1085.85	1111.25	1054.1	1073.15	1104.9	1200.15
40	1009.65	1003.3	1000.25	1009.65	1060.45	1028.7	1022.35	1025.65	1047.75	1098.55	1070.1	1070.1	1076.45	1098.55	1149.35	1162.05	1114.55	1127.25	1155.7	1250.95
42	1050.45	1054.1	1051.05	1066.8	1111.25	1079.5	1073.15	1076.45	1104.9	1149.35	1123.95	1120.9	1127.25	1155.7	1200.15	1219.2	1165.35	1178.05	1219.2	1301.75
44	1111.25	1104.9	1104.9	1111.25	1155.7	1130.3	1130.3	1130.3	1162.05	1206.5	1178.05	1181.1	1181.1	1212.85	1257.3	1276.35	1219.2	1231.9	1270	1368.55
46	1162.05	1152.65	1168.4	1162.05	1219.2	1181.1	1178.05	1193.8	1212.85	1270	1228.85	1228.85	1244.6	1263.65	1320.8	1327.15	1273.3	1289.05	1327.2	1435.1
48	1212.85	1209.8	1206.5	1219.2	1270	1231.9	1235.2	1244.6	1270	1320.8	1279.65	1286	1295.4	1320.8	1371.6	1384.3	1324.3	1346.2	1390.7	1485.9
50	1263.65	1244.6	1257.3	1270		1282.7	1295.4	1295.4	1320.8		1333.5	1346.2	1346.2	1371.6		1435.1	1377.95	1403.35	1447.8	
52	1314.45	1320.8	1308.1	1320.8		1333.5	1346.2	1346.2	1371.6		1384.3	1397	1397	1422.4		1492.25	1428.75	1454.15	1498.6	
54	1358.9	1352.55	1352.55	1377.95		1384.3	1403.35	1403.35	1428.75		1435.1	1454.15	1454.15	1479.55		1549.4	1492.25	1517.65	1555.8	
56	1409.7	1403.35	1403.35	1428.75		1435.1	1454.15	1454.15	1479.55		1485.9	1504.95	1504.95	1530.35		1606.55	1543.05	1568.45	1612.9	
58	1460.5	1447.8	1454.15	1473.2																

1. SPIRAL WOUND GASKETS

LOAD BEARING GASKETS

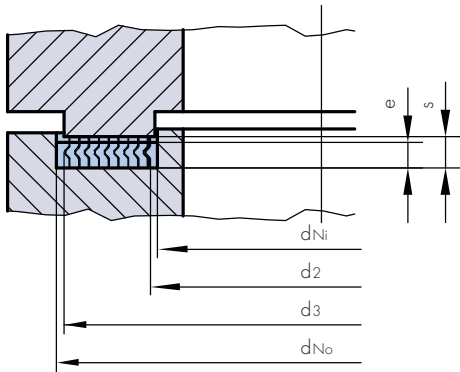

Gasket compression

Spiral-wound gaskets shall be designed in such a way that a uniform bolt stress, based on the nominal root diameter, will compress the gasket to a thickness (e).

STANDARD GASKET COMPRESSION			
s	3.2	4.5	6.5
e	2.5 ^{+0.1}	3.3 ^{+0.1}	4.7 ^{+0.1}

Connections with non-load bearing gaskets

Since no standards exist as yet for the use of spiral-wound gaskets in no-load bearing connections, the application of guidelines from the adjacent table is recommended.

Gaskets and grooves dimensions

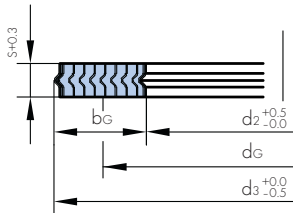

SPIRAL-WOUND GASKET				GROOVE				
d _M	s	b _G	d ₃	d ₂	d _{NO}	b _N	d _{NI}	t _N
< 300	3.2	5-9	d _G + b _G	d _G - b _G	d ₃ + 1	b _G / 0.86	d _{NO} - 2b _N	2.5 ^{+0.1}
< 1000	3.2	9-17	d _G + b _G	d _G - b _G	d ₃ + 1.5		d _{NO} - 2b _N	2.5 ^{+0.1}
< 300	4.5	5-9	d _G + b _G	d _G - b _G	d ₃ + 1		d _{NO} - 2b _N	3.3 ^{+0.1}
< 1000	4.5	9-17	d _G + b _G	d _G - b _G	d ₃ + 1.5		d _{NO} - 2b _N	3.3 ^{+0.1}

b_G-gasket width

b_N-groove width

Tolerance Table

FLANGE SIZE		PROJECTION AND RECESS			SMOOTH CONTACT FACE					
NPS (in)	DN (mm)	d2	d3	s1	d1	d2	d3	d4	s1	s2
< 10"	< 300	±0.5	±0.5	+0.8 +0.1	±0.8	±0.8	±0.8	±0.8	+0.8 +0.1	+0.25 -0.15
10" - 24"	300 - 700	±0.8	±0.8	+0.8 +0.1	±0.8	±0.8	±0.8	+0.8 -1.6	+0.8 +0.1	+0.25 -0.15
26" - 50"	800 - 1200	±1.2	±1.2	+0.8 +0.1	±1.6	±1.6	±1.6	+0.8 -2.0	+0.8 +0.1	+0.25 -0.15
> 50"	> 1200				±2.4	±2.4	±2.4	+0.8 -3.0	+0.8 +0.1	+0.25 -0.15

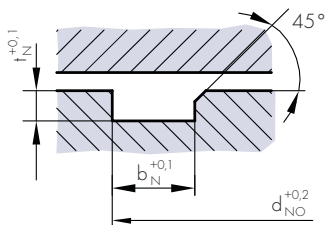

Gasket parameters

Gasket Type	MATERIAL (Jacket)	DIN 2505		ASME	
		k ₁ [mm]	k ₀ xk _D [N/mm]	m	y [MPa]
MS 10, MS 12, MS 14, MS 16	Steel, Cr-Steel	1.3xb _D	50xb _D	1.3	50
	CrNi-Steel, Monel	1.4xb _D	55xb _D	1.4	55
	CrNi-Steel (Graphite/PTFE)	1.2xb _D	40xb _D	1.2	40

1. SPIRAL WOUND GASKETS

All standard and non-standard types can be delivered in non-standard dimensions according to customer request.

EN 1092 and ASME B 16.5 TONGUE and GROOVE flanges meet SWG dimensions according to ASME B 16.21 or other customer request.

EN 1092 and ASME B 16.5 MALE and FEMALE flanges meet SWG dimensions according to ASME B 16.21 or other customer request.

NON-STANDARD SWG

Gaskets for Boilers Handholes and Manholes:

Gaskets Type MS 10 can be manufactured in other shapes like oval and oblong (stadium). There is no specific standard for this type of gasket. When ordering it providing complete specifications is required: inside dimensions (AxB), width (b) and thickness (s) or a drawing.

GASKET ORDERING EXAMPLE

Spiral wound gasket MS 10,
A x B x b x s,
Winding: AISI 316,
Filler: Graphite 98%

Spiral wound gasket MS 16,
ASME B 16.20 for ASME B 16.5, 2"-150lbs,
Winding, inner ring: AISI 316,
Filler: Graphite 98%,
Centering ring: CS

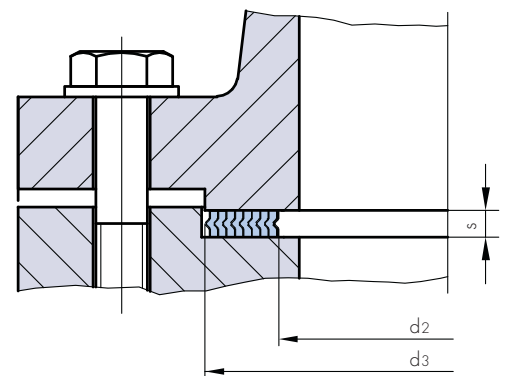
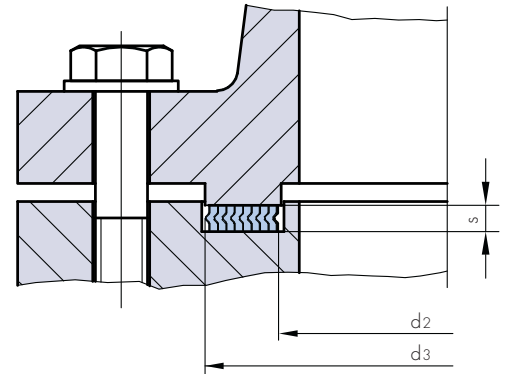

Oval shape

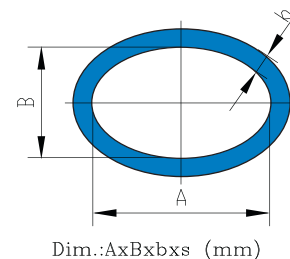

Oblong (stadion) shape

